



A Member of the
COLFAX PUMP GROUP

Screw pumps

Medium and high pressure pumps

Installation and Start-up Instruction

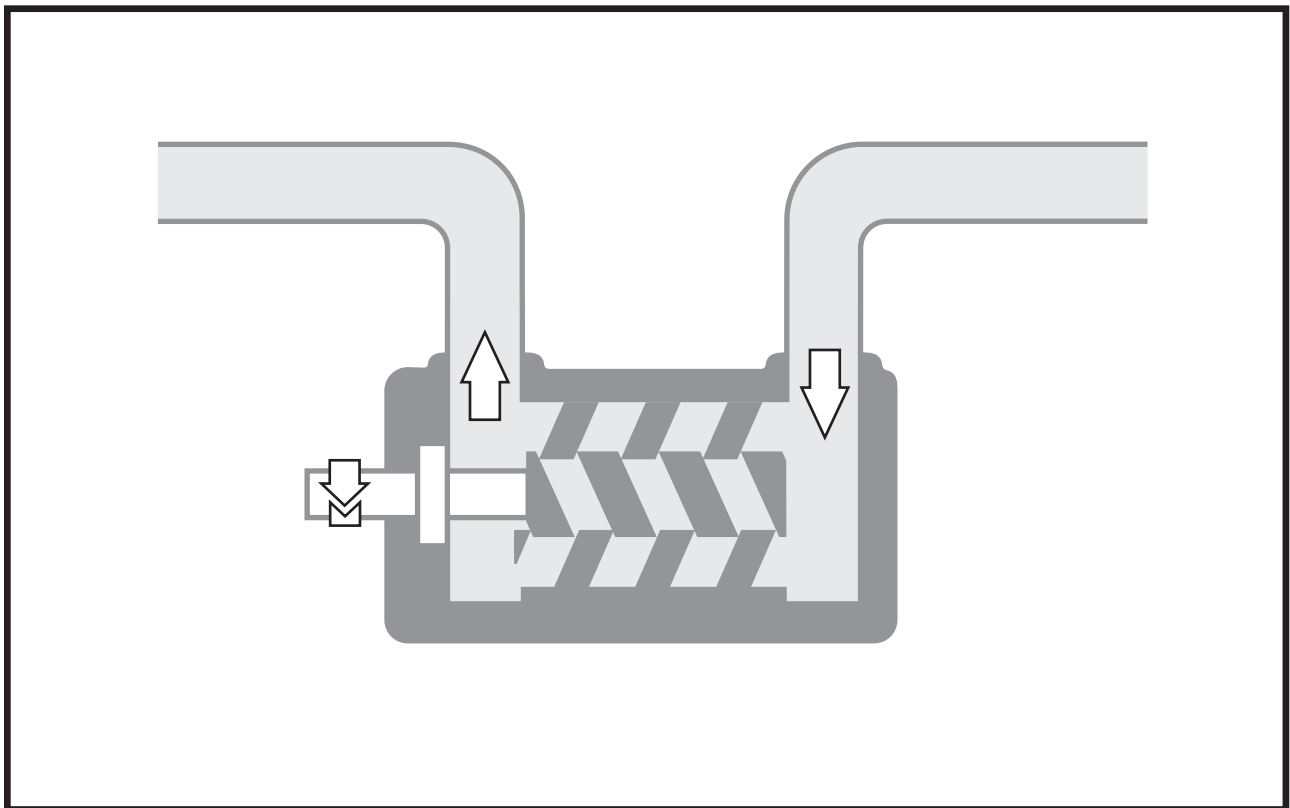







This instruction is valid for all standard high pressure pumps: E4, D4 and D6	
Contents	Page
Pump identification	2
Installation	3
Start-up	8
Trouble shooting	10

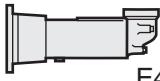

Before commencing any work, read this instruction carefully! Failure to comply with these instructions may cause damage and personal injury!

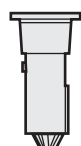
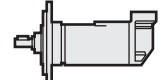
These instructions are valid for all medium and high pressure pumps as specified in the Pump identification chart below.

Pump identification

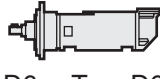
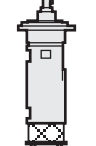
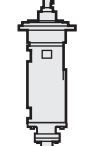
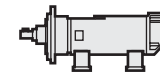
Pump name	Size (1)	Rotor lead (1)	Design modification (1)	Material pump casing (1)	Shaft seal design (1)	Moun-ting (2)	Valve/ other (3)	Also valid for option	Com-ments
 E4 xxBE  E4 xxJE  E4 xxTE	025 032 038 045 052 060 070	K L N	1 4	L Y	E R V	B J T	E	A101 A141 A259 A260 A314 A337 G067 G101 G259 G260 G314	
 D4 xxBE  D4 xxBP  D4 xxTE  D4 xxJE	025 032 038 045 052 060 070	K L N	2	L Y	R T V	B J T	E P	A056 A101 A117 A246 A333 G056 G101 G117 G246 G333	
 D6 xxBx  D6 xxTx  D6 xxJx  D6 xxFx	038 045 052 060 070	K N	3	S	R T V	B F J T	Y Z	A101 A309	

(1) See Product Description or Maintenance Instruction

(2) B = Flange mounting
F = Foot mounting
J = For vertical tank mounting with prolonged inlet pipe

T = For vertical tank mounting with mounted strainer
3) E = Without valve
P = With Valve
Y = External ball bearing
Z = Internal ball bearing

Option

A101/G101
A246/G246
A337

} Pumps with CCW-rotation

Identification of safety instructions

Non compliance of safety instructions identified by the following symbol - could affect safety for persons.



Safety instructions where electrical safety is involved, are identified by:



Safety instructions which shall be considered for reasons of safe operation of the pump or pump unit and/or protection of the pump or pump unit itself are marked by the sign:

ATTENTION

Installation

BEFORE COMMENCING ANY WORK, READ THIS INSTRUCTION CAREFULLY!

Design limitations and technical data for each pump are found in the **Product description**.

Installation of IMO AB medium and high pressure pumps does not require special skills. However, these instructions presume that the work is carried out by experienced fitters.

Maintenance and service instructions, which are specific for each pump are presented in a separate document.



Failure to comply with these instructions may cause damage and personal injury!

Transport and storage

The pump shall always be protected against ingress of water and other impurities. The pump shall always be stored in a clean, dry and warm environment. The pump is delivered with the internals oiled and with protective covers. These covers should remain in place for as long as possible during the mounting and installation procedure but must be removed before start up.

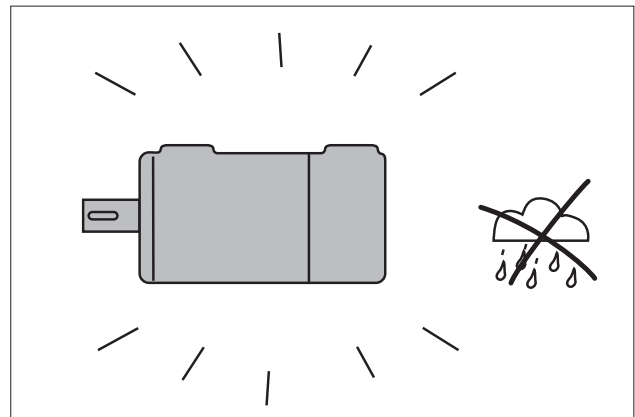

Fig. 1 Clean and dry environment



All work carried out on the pump has to be performed in such a manner that risks for personal injury are observed!

Lifting of pump



All pumps should be lifted with straps securely attached to the pump or pump unit, so that the centre of gravity is located between the straps in order to avoid tipping of the pump.

Lifting of the complete pump unit with the lifting device attached to the motor, should be avoided as the motor's lifting provisions may not be able to carry the combined weight of the pump and motor.



When lifting a complete pump unit, using slings or hooks attached to the pump or connecting frame make sure that the centre of gravity is located below the points of attachment or that sufficient protection against tipping is provided otherwise.

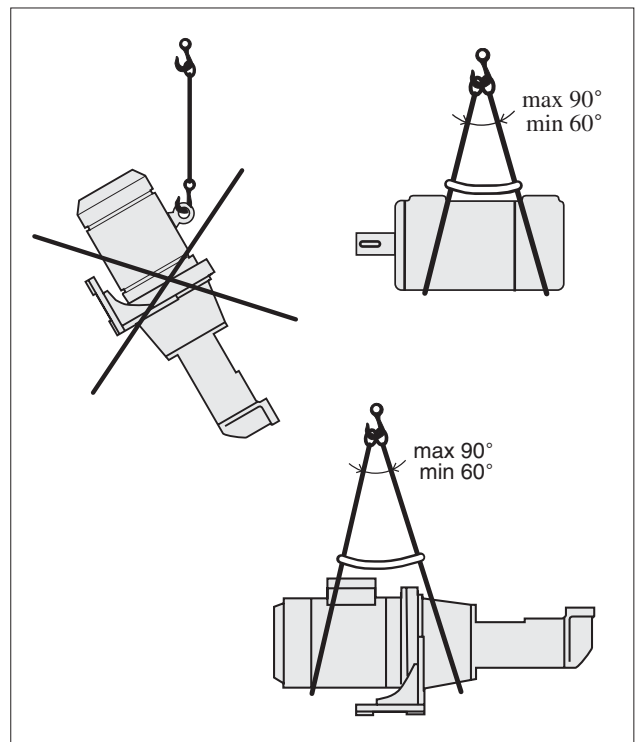

Fig. 2 Lifting of pump

Mounting

The pump must be securely mounted on a firm stable foundation and positioned so that it is easily accessible for inspection and servicing. Provisions for collecting oil spillage when servicing the pump are to be installed.

ATTENTION

The installation must always be designed to minimise damage should an operational or functional failure occur.

Provisions should be installed to collect oil spillage if a functional failure results in a broken pipe or pump housing.

The pump installation should be provided with an emergency shutdown to avoid damages due to overheating or if the oil volume is below a minimum tank level.

Alignment and shaft couplings

The pump shall be connected to its driver via a flexible shaft coupling. The pump may also be driven via gears or pulleys as specified in the Product Description, provided the radial forces are kept within the specified range. We recommend that the pump is connected via our standard connecting frame and IMO AB standard coupling. The coupling and alignment shall be selected not to exert any axial or radial loads on the shaft ends. IMO AB standard couplings shall have a distance between the coupling halves as per table, fig. 4 the coupling halves shall be secured by lock screws. For other types of couplings, please refer to respective maker's instructions.

For direct driven pumps the alignment between pump and motor shafts must be kept within the limits according to fig. 3 and 4.

! Measures shall be provided to avoid accidental contact with the rotating shaft coupling. Any installed coupling guard shall permit easy access to the pump shaft for maintenance and inspection of the pump bearing and seal housing.

! When handling liquids that may harm skin use gloves and/or protective clothing.

! When handling liquids which may involve fire hazards appropriate precautions to avoid danger are to be taken.

! In case of failure for a system with elevating pressure fluid jets may cause injury and/or damage.

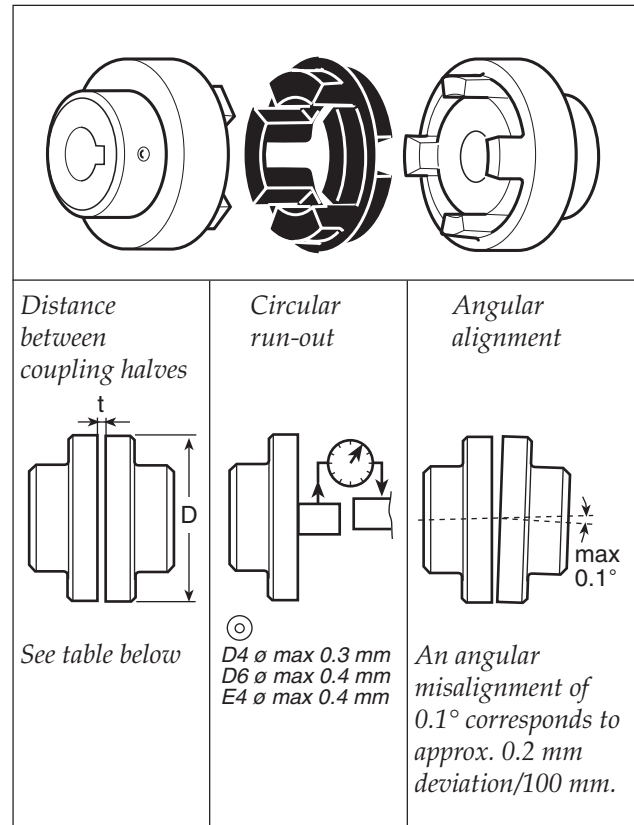

Fig. 3 Alignment of the IMO AB standard coupling

Outer diameter of coupling (D mm)	Distance between coupling halves (t mm)	Outer diameter of coupling (D mm)	Distance between coupling halves (t mm)
50	2.0	148	3.5
67	2.5	168	3.5
82	3.0	194	3.5
97	3.0	214	4.0
112	3.5	240	4.0
128	3.5		

Fig. 4 Distance between coupling halves (IMO AB standard coupling)

Pipe connections

The pipe work should be installed and supported so as not to exceed any permitted loads and transfer to the pump casing.

The pipe work should be tight in order to avoid leakage and ingress of foreign particles and/or air. Shut off valves should be installed in the discharge line and when appropriate in the suction line (not tank mounted version), so that the pump can be hydraulically isolated.

Welding of counter flanges must be performed in such a way that no weld slag etc. can enter into the pump. Pumps delivered with counter flanges from IMO AB have a protection plate which shall be removed after that welding is completed.

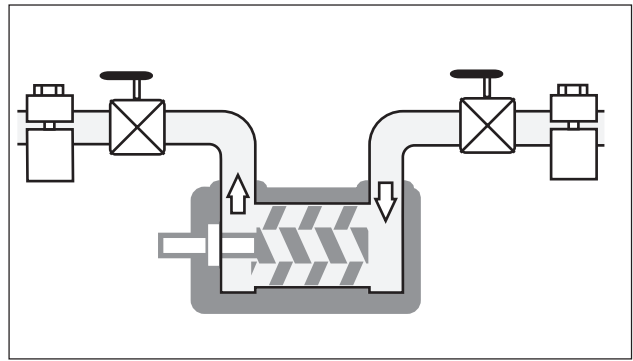

Fig. 5 Pipe connections

Suction line

The suction line should be designed so that the total pressure drop, measured at the pump inlet flange, does not exceed the suction capability of the pump. Make a proper calculation of the suction line including components such as valves, strainer, pipe bends etc.

Generally, the pressure drop in the suction line should be as low as possible, which is achieved if the suction pipe is short, straight and has a suitable diameter.

The velocity in the suction line should be kept in the range 0.5 - 1.2 m/s.

The suction line must be equipped with a port that allows filling the pump before start.

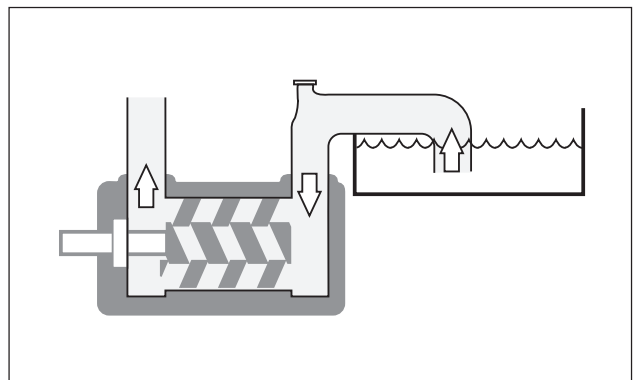

Fig. 6 Suction line

Discharge line

The discharge line should be dimensioned to keep the velocity in the range 1 - 3 m/s.

De-aeration

In installations with negative suction head, where the pump might be started against a pressurized system, a de-aeration pipe with a suitable dimensioned orifice has to be installed, see fig. 7. The de-aeration pipe should be connected to the highest point of the outlet pipe.

This must also be installed when the pump is used as a stand-by pump.

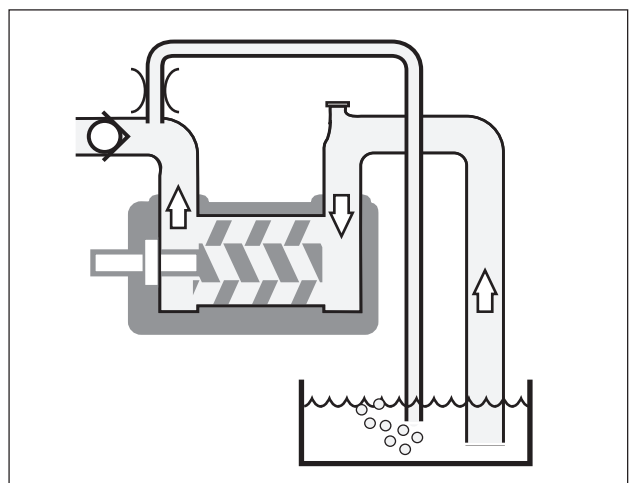

Fig. 7 De-aeration

Cleanliness

The pump has to be protected from foreign matter, such as weld slag, pipe scale, etc., that could enter the pump via the suction line. If the cleanliness of the system cannot be guaranteed, a strainer must be installed in the inlet pipe near the pump.

The size of the strainer should be selected so that it is large enough to allow adequate pressure at the pump inlet. The pressure drop across the strainer should preferably not exceed 0.1 bar at max. flow rate and operating viscosity. A vacuum gauge between the strainer and the pump inlet is recommended to indicate when the strainer needs cleaning.

Some pumps are equipped with inlet strainers in standard design, mesh size 0.5 mm. For other pumps, strainers with the same mesh size are recommended.

To further extend the service life of the pump improved cleanliness is recommended.

For hydraulic oils a cleanliness of at least 19/16 according to ISO 4406 at pressure > 16 bar and at least 20/16 at lower pressure is recommended.

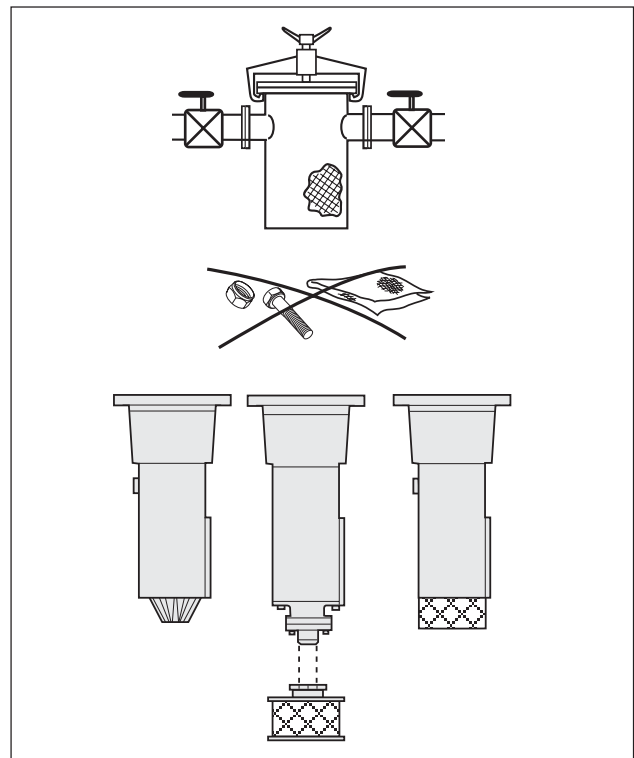

Fig. 8 Cleanliness

Liquid trap

In some mounting arrangements (xxBx and xxFx) the pump may not retain the liquid at stand still. In such installations the suction pipe should be arranged so it forms a liquid trap together with the pump. See fig. 9.

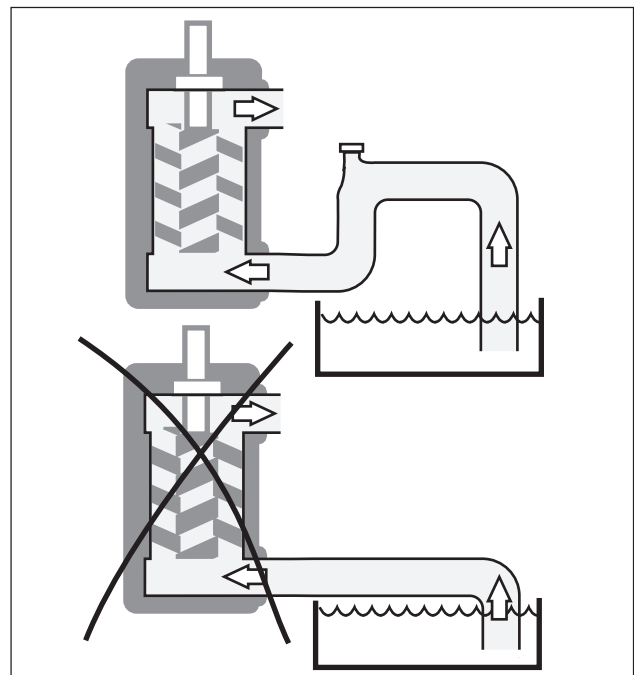

Fig. 9 Liquid trap

Safety valve

Pumps not equipped with an internal valve require a separate relief valve connected to the delivery pipe to limit fluid pressure. Locate the pressure relief valve as close to the pump outlet port as possible, preferably upstream of a check valve, where so equipped. The return line from the valve should be run back to a suitable position in the tank to limit the temperature rise in the pump when overflow takes place.

Set the valve opening pressure as low as corresponding to satisfactory system performance. Do not choose an opening pressure in excess of the maximum operating pressure of the pump.

The D4 xxBP pump is supplied from IMO AB with an integrated pressure relief valve designed for external overflow. The return line from the pressure relief valve should be run back to the tank to limit the temperature rise in the pump when overflow takes place.

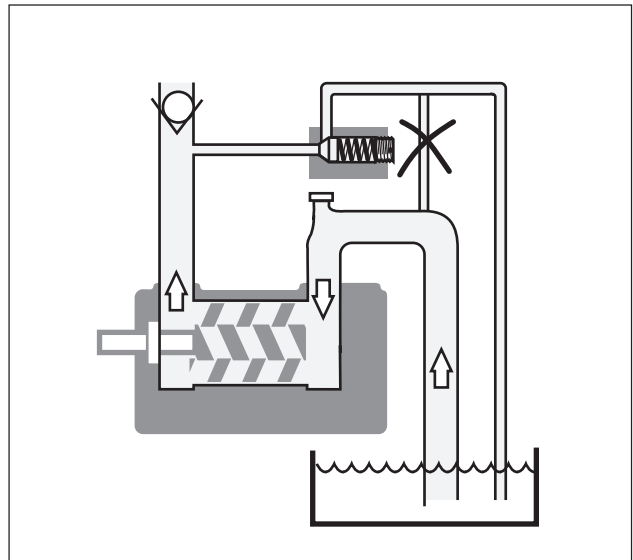



Fig. 10 External pressure relief valve

Pressure testing and flushing

The system must be flushed with the pump replaced by a dummy pipe and pressure tested before connecting the pump.

If corrosive liquid, such as water is used, the system must be thoroughly drained, dried and protected against corrosion before the pump is reinstalled as otherwise the pump might be damaged before start-up due to internal corrosion.

 Oil leakage may make the floor slippery and cause personal injury.

Pressure gauge

There should be a tap point for connecting a pressure gauge to the delivery pipe to adjust and check the setting of the pressure relief valve.

Some pumps are equipped with pressure taps.

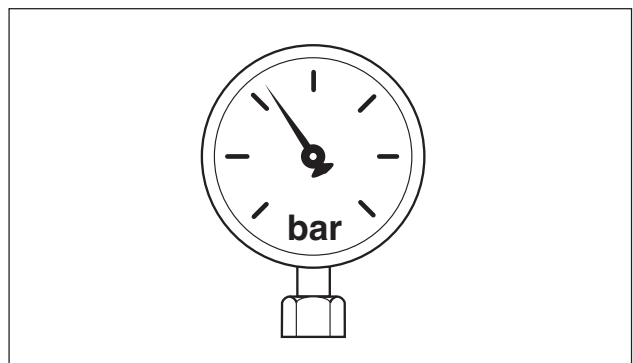

Fig. 11 Pressure gauges

Start-up

Before starting

After installation or whenever it can be assumed that the pump has been emptied, the pump must be thoroughly filled with liquid. See chapter "Suction Line", page 5.

⚠ Make sure the prime mover is disconnected and can not be started accidentally.

While filling the pump rotate the shaft by hand. If the shaft is not accessible, rotation can be performed from the motor fan, to ensure that the rotor bores and the shaft seal compartment is filled.

⚠ Do not forget to fit the motor fan cover again before making start of motor possible.

Open the shut-off valves in the inlet and delivery pipes to the full extent. Set pump pressure relief valve at the lowest opening pressure. The pump is now ready for starting.

If the suction pipe cannot be completely filled, it is important to ensure that the trapped air is evacuated without any pressure build up. (See fig. 7 Deaeration).

ATTENTION

Starting a dry pump is likely to cause damage to the pump.

Direction of rotation

When the pump is ready to be started, switch the motor briefly on and off and check that the drive motor rotates in the correct direction as indicated by the rotation arrow. Check the direction of rotation by watching the fan on the electric motor.

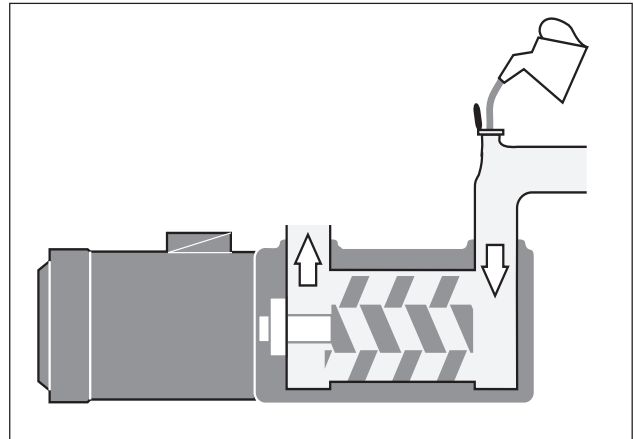

Fig. 12 Filling the pump before starting

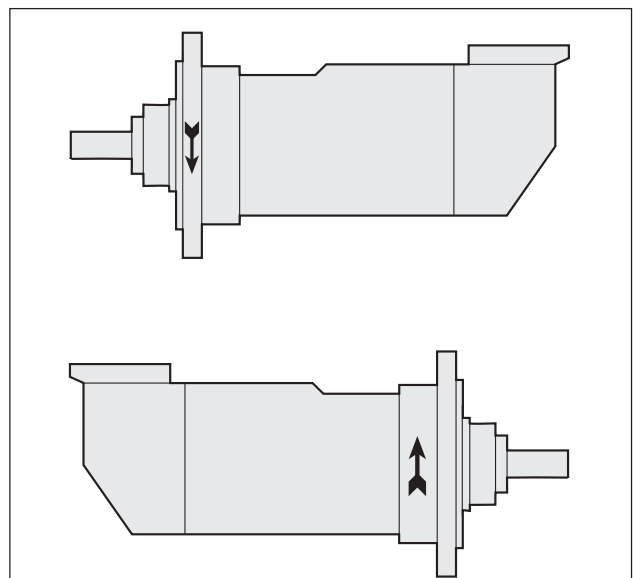

Fig. 13 Direction of rotation

Starting

Set the pumps pressure relief valve to low pressure and start the pump with the valves in the inlet and delivery pipes fully open. When the pump begins discharging fluid, "has primed", raise the pressure to 1.0-1.5 bar or slightly below the system pressure if this is lower. Allow the pump to run for a few minutes until air has been evacuated from the system and the fluid is free of bubbles, adjust the pump pressure for the rated value of the system. If the pump fails to prime, do not run it for more than a few seconds. Repeat the start procedure a few times at intervals of a few minutes. If this proves unsuccessful, there is a fault condition in the system. See "Trouble shooting".

ATTENTION

Because of design principle the D4 pump must reach a minimum of discharge pressure (as per fig. 14) immediately after start to prevent failure.



If operating temperature exceeds 60°C, appropriate measures to avoid burn injury shall be provided.



Use hearing protections whenever high noise can be expected from pump, motor and/or environment.

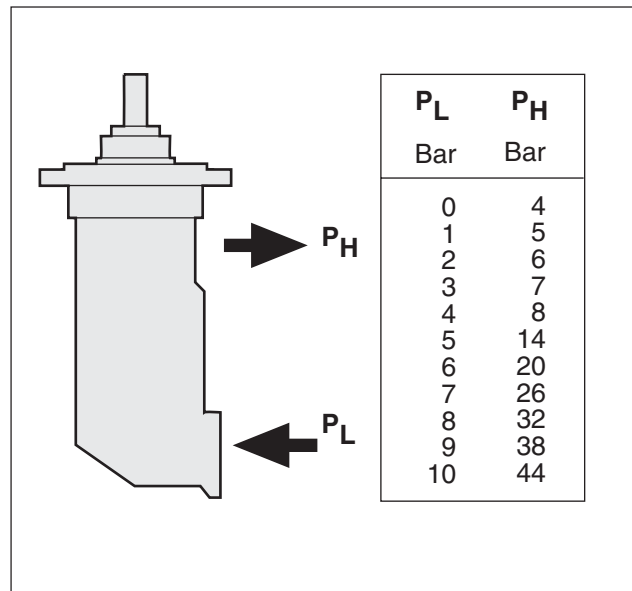





Fig. 14 Minimum discharge pressure at given inlet pressure for D4 pump

Trouble shooting

Disturbance	Cause	What to do
<p>1. The pump cannot be primed.</p> <div style="background-color: #e0e0e0; padding: 5px; margin-top: 10px;">  <p>Connecting and disconnecting of electric cables must be done only by personnel authorized to do such work.</p> </div>	<ul style="list-style-type: none"> - Wrong direction of rotation. - Suction line is not open or pressure drop in the suction line is too high. - Major air leakage into the suction line. - The pump cannot evacuate the air through the discharge line due to excessive counter pressure. 	<p>Reverse the terminal connection on electric motor.</p> <p>Check all components in suction line. The inlet condition should be checked with a vacuum gauge at the pump inlet.</p> <p>Check the suction line.</p> <p>See de-aeration (page 5).</p>
<p>2. No flow.</p>	<ul style="list-style-type: none"> - The pump is not primed. - The pressure relief valve is set below the counter pressure. 	<p>See above.</p> <p>Re-adjust the pressure relief valve to a value above counter pressure.</p>
<p>3. Flow too low.</p>	<ul style="list-style-type: none"> - The pressure relief valve is set too low (Discharge pressure also low). - Something is restricting the flow in the suction line. (This would usually cause noise). - The pumped liquid contains a significant amount of compressible gas, such as free air. (This would usually cause noise). 	<p>Re-adjust the pressure relief valve.</p> <p>Check all components in the suction line.</p> <p>See the chapter on Noise and Vibrations. (Page 11).</p>
<p>4. Pressure too low.</p>	<ul style="list-style-type: none"> - The pressure relief valve is set too low. - System open for unintended bypass or malfunctioning or wrongly operated components in the system. - A too small pump has been chosen. 	<p>Re-adjust the pressure relief valve.</p> <p>Check the components in the discharge line.</p> <p>Check the valve. See the Maintenance and Service instruction for the pump.</p>
<p>5. Pressure too high.</p>	<ul style="list-style-type: none"> - The pressure relief valve is set too high. - The oil is too cold (or has higher viscosity than anticipated). - Counter pressure in the discharge line is too high. 	<p>Re-adjust the pressure relief valve.</p> <p>Reduce the pressure setting until operational temperature has been reached.</p> <p>Check the dimensioning of the discharge line.</p>

Disturbance	Cause	What to do
<p data-bbox="177 327 512 443">6. Drive motor difficult to start or tends to stop by tripping the motor overload relay.</p> <div data-bbox="165 685 568 904" style="background-color: #e0e0e0; padding: 5px;">  <p data-bbox="252 707 520 880">Connecting and disconnecting of electric cables must be done only by personnel authorized to do such work.</p> </div>	<ul style="list-style-type: none"> <li data-bbox="596 327 932 360">- Counter pressure too high. <li data-bbox="596 387 804 421">- Liquid too cold. <li data-bbox="596 707 940 768">- Motor is undersized for the prevailing conditions. <li data-bbox="596 795 978 828">- Electrical power supply faulty. <li data-bbox="596 884 1002 945">- Motor overload relay set too low or is faulty. <li data-bbox="596 972 986 1005">- Incorrect setting of Y/D starter. 	<p data-bbox="1018 327 1362 360">See above: Pressure too high.</p> <p data-bbox="1018 387 1417 678">Re-adjust the pressure relief valve to a lower value. Thus the power consumption for the pumping is relieved and overloading due to the high viscosity may be avoided. When the liquid has reached normal temperature and thus flows easily, the pressure relief valve is reset to normal pressure.</p> <p data-bbox="1018 707 1219 741">Check the motor.</p> <p data-bbox="1018 795 1362 855">Check the power supply, the motor and motor connection.</p> <p data-bbox="1018 884 1362 918">Re-adjust or replace the relay.</p> <p data-bbox="1018 972 1337 1032">Re-adjust the setting of the starting sequence.</p>
<p data-bbox="177 1144 469 1178">7. Noise and vibrations.</p> <div data-bbox="165 1205 568 1361" style="background-color: #e0e0e0; padding: 5px;">  <p data-bbox="252 1227 552 1346">Monitor the pump function and shut down if any sign of malfunction is noticed.</p> </div> <div data-bbox="165 1509 568 1729" style="background-color: #e0e0e0; padding: 5px;">  <p data-bbox="252 1532 520 1704">Connecting and disconnecting of electric cables must be done only by personnel authorized to do such work.</p> </div>	<ul style="list-style-type: none"> <li data-bbox="596 1144 991 1205">- The flow to the pump is insufficient. <li data-bbox="596 1261 940 1321">- Insufficient support of pipe work. <li data-bbox="596 1406 828 1440">- Wrong alignment. <li data-bbox="596 1467 997 1500">- Air leakage into the suction line. <li data-bbox="596 1556 935 1617">- Free air in the liquid or gas cavitation. <li data-bbox="596 1644 895 1677">- Faulty electrical supply. 	<p data-bbox="1018 1144 1417 1234">Check the liquid level in the tank. See also chapter: The flow is too low.</p> <p data-bbox="1018 1261 1394 1379">Check for pipe vibrations in the pump connections. Check that the pipes are sufficiently clamped.</p> <p data-bbox="1018 1406 1362 1440">Check alignment, see page 4.</p> <p data-bbox="1018 1467 1362 1527">Check the suction line for air leakage.</p> <p data-bbox="1018 1556 1417 1590">Contact your IMO representative.</p> <p data-bbox="1018 1644 1362 1704">Check all three phases of the supply.</p>



A Member of the
COLFAX PUMP GROUP

www.imo.se

IMO AB:

P. O. Box 42090, SE 126 14 Stockholm, Sweden

Telephone: +46 8 50 622 800, Telefax: +46 8 645 1509